

# JRC

## SERIES REVERSE CIRCULATION DRILLING RIG

### JRC系列反循环钻机

#### RC DRILLING KNOW HOW

- >> Reverse Circulation is a drilling method widely used around the world.
- >> RC drilling uses dual wall drill rods consisting of an outer drill rod with an inner tube. These hollow inner tubes allow the drill cuttings to return back to the surface in a continuous, steady flow.
- >> The advantage of this drilling technique is that it produces large quantities of high quality, reliable samples free of cross-contamination. The cuttings also allow surveyors to locate mineral deposits more precisely as the samples are identified by the exact depth and location that they were found.
- >> RC drilling produces dry rock chips, large air compressors dry the rock ahead of the advancing drill bit. It is slower, but achieves better penetration than other types of drilling.
- >> Conventional DTH and Top Hammer collar sampling are likely to experience unwanted material collection, as the desired sample is blown to the surface via the hole annulus and contaminated by the prior sample intervals.

#### CHARACTERISTICS OF RC DRILLING

- >> JRC200 reverse circulation drilling rig is a new multi-purpose, high-efficiency, environmental protection, multi-track-type rig, which uses the latest foreign gas lift reverse circulation drilling technology, rock dust can be effectively collected through a dust collector to avoid environmental pollution. You can also collect slagging cyclone separator can be used in geological prospecting department of sampling analysis. It is a geological exploration drilling, drilling wells, monitoring wells, ground source heat pump air-conditioning and other deep hole of choice for equipment.
- >> The drilling rig can be used in a variety of compressed air on the ground hole reverse circulation drilling. The lifting system, guide compensation, drill pipe loading and unloading, rotation and feed, legs, winch, walking and other system to achieve all of the hydraulic system to significantly reduce the labor intensity and improve the efficiency and quality of construction .



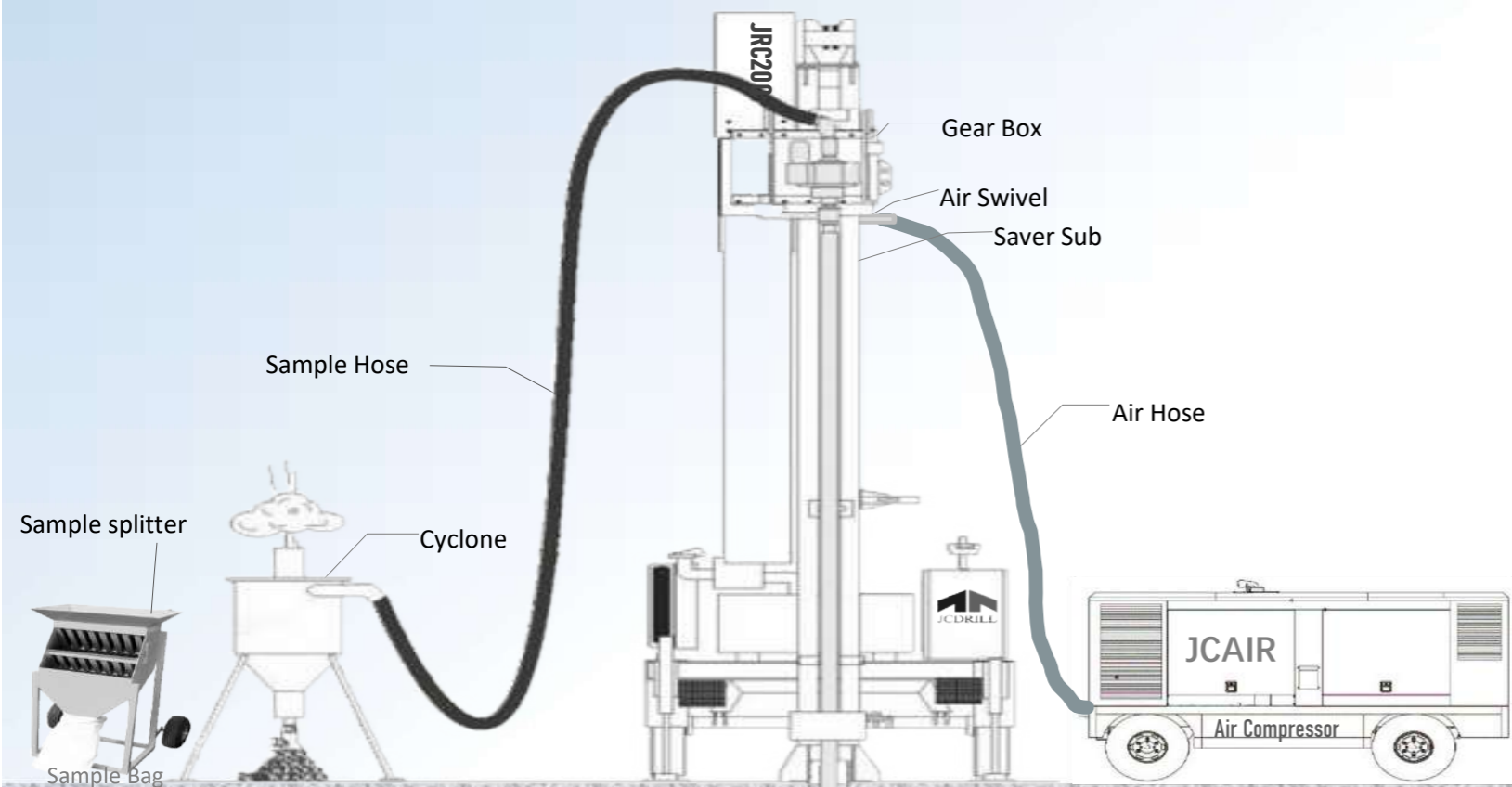

Bottom of Hole

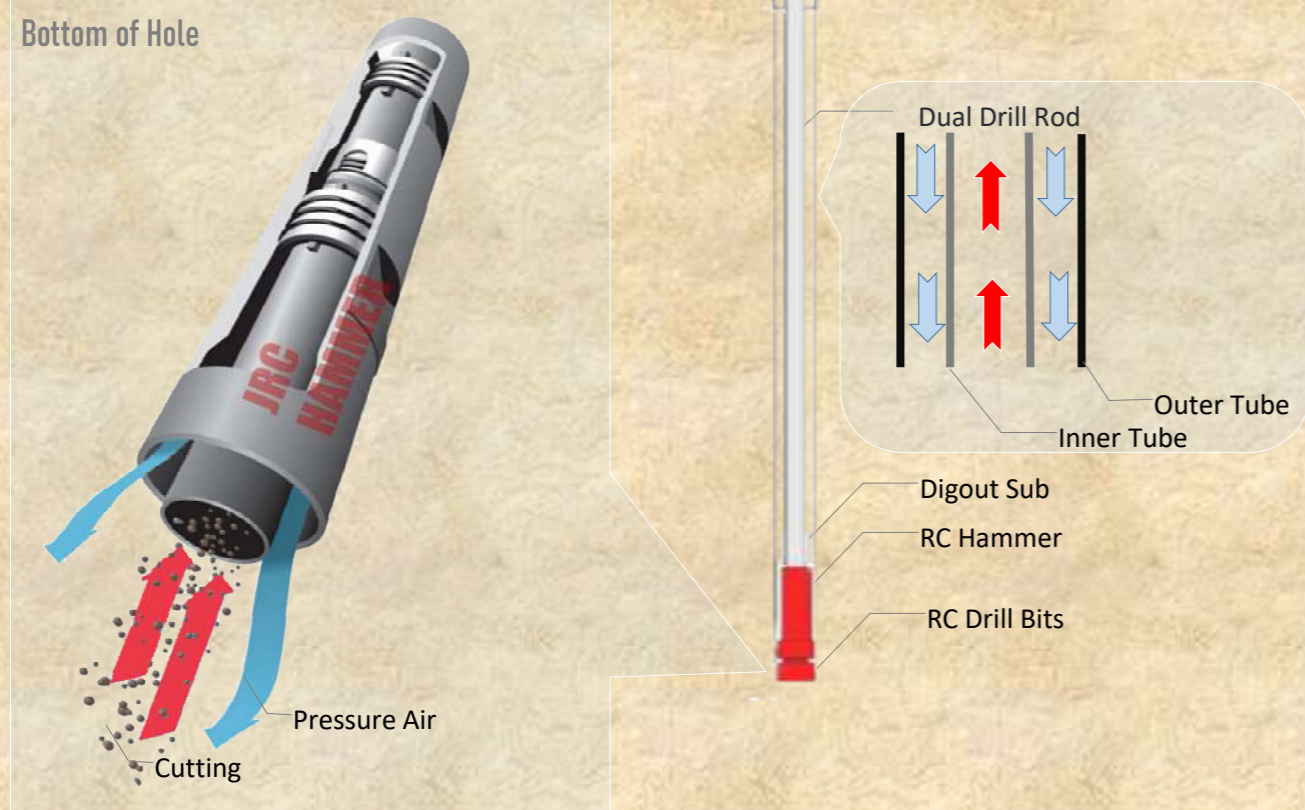



# JRC200

JRC200 reverse circulation drilling rig is a new multi-purpose, high-efficiency, environmental protection, multi-track-type rig, which uses the latest foreign gas lift reverse circulation drilling technology, rock dust can be effectively collected through a dust collector to avoid environmental pollution. You can also collect slagging cyclone separator can be used in geological prospecting department of sampling analysis. It is a geological exploration drilling, drilling wells, monitoring wells, ground source heat pump air-conditioning and other deep hole of choice for equipment.

### Specification 技术参数

Spc.	Unit	JRC200
Geology drilled		All kinds
Drilling Type		DTH & RC
Drill system and operation		Hydraulic
Max.Hole Diameter	mm	Φ105—Φ350
Max.Hole Depth	m	RC:200 DTH:200
Rotation Torque	N.M	4500-6500
Rotation Speed	rpm	0-100
DTH Drill pipe diameter	mm	89/102/114
RC Drill pipe diameter	mm	89/102/114
Drill pipe length	mm	3000
Max. Feed Speed	M/min	5-30
Max. Lifting Speed	M/min	5-18
Feed Stroke	mm	3700
Max. Pull back force	T	12
Max.Push Down Force	T	6
Lifting force of tool winch	T	1.1
<b>Engine</b>		
Diesel Engine type		Cummins
Rated Horse power	Kw	74
Electrical System	Volt	24
<b>Hydraulic Clamp(Optional)</b>		
Max.Size	mm	140
Cylinder Quantity	Pcs	5
<b>Dimension</b>		
Net Weight	Kgs	6000
Shipping Size(L*W*H)	mm	5760*1800*2400
Working Size(L*W*H)	mm	4800*3150*6500
Hydraulic Leg Feed Stroke	mm	600
Gradeability	°	25
Ground Clearance	mm	300
Walking Speed	Km/h	2.5



### Characteristics 产品特点

- >> Diesel engine mounted hydraulic system, all the system include the walking, rotation, feed, lifting, Leg, lifting, compensation system, rod change is hydraulic.
- >> Reverse circulation system working together with DTH technology, air compressor provide pressed air for impact and dust collect.
- >> During working, use the reverse circulation hammer, double tube, pressed air enter between two tube and dust out from the inner tube.
- >> Also it's available to positive circulation use normal drilling tool.
- >> The working system composed of feed system, guide(mast), rotary head, compensation system, centralizer, rod exchange system, winding and so on.
- >> Axes pressure, feed speed, rotary speed is adjustable.
- >> The walking system is a self-walking system, convenient for moving, which could install four hydraulic leg, when load on truck, it doesn't need hiking up, it can load on truck directly.
- >> Four hydraulic leg use for keep the balance of the drilling during working.
- >> The drilling rig can be used in a variety of compressed air on the ground hole reverse circulation drilling. The lifting system, guide compensation, drill pipe loading and unloading, rotation and feed, legs, winch, walking and other system to achieve all of the hydraulic system to significantly reduce the labor intensity and improve the efficiency and quality of construction.

# JCDRILL

## The best RC drilling solution!



PROFESSIONAL TEAM



QUALITY GUARANTEED



24 HOURS ONLINE



24 HOURS SERVICE



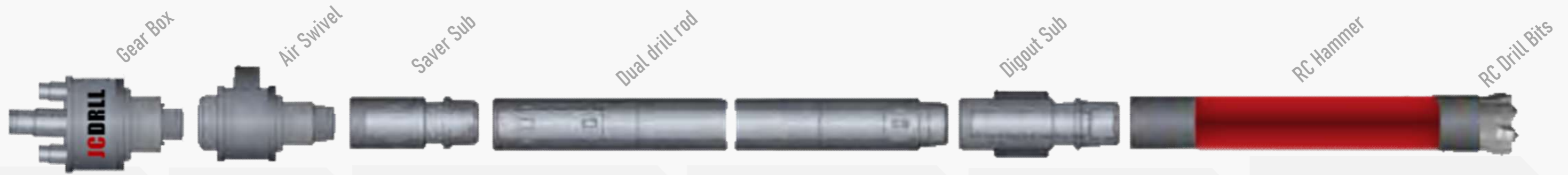

>> We provide gear box driven by two hydraulic motor, which can use for 150/200/300/400/500m and 115 to 178mm RC hole drilling.

>> The side inlet swivel distributes pressure air in between the outer tube and inner tube.

>> The saver sub protects the threads on the rotation head. The saver sub thread comes into contact with all the other thread in the drill string and should be replaced frequently to reduce the risk of adamaged

>> The dual-wall pipe supplies air to the hammer through the annulus between the inner and outer pipe, and transports cuttings inside the inner tube for sampling.

>> A digout sub is a short crossover sub between the hammer and pipes. With 4 bars, It stabilizes the hammer and prevents damaged to the hammer when digging out

>> High frequency reverse circulation hammer offer worldclass performance and reliability in all rock formation, with 15-20 percent higher penetration than conventional tools.

## Reverse Circulation

We offer a complete RC drilling string.

Scan here to find us



WECHAT



WHATSAPP

# JCDRILL

RC hammer & Bits 4-7"



RC Drilling Rigs  
反循环钻机



RC Drilling Products  
反循环相关产品

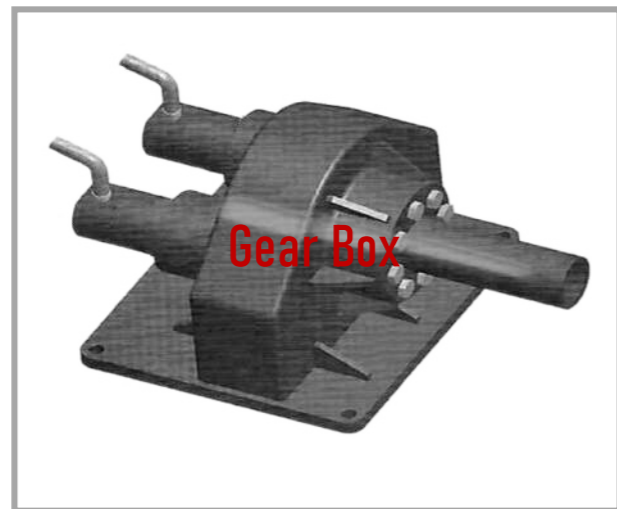



In Project  
施工现场

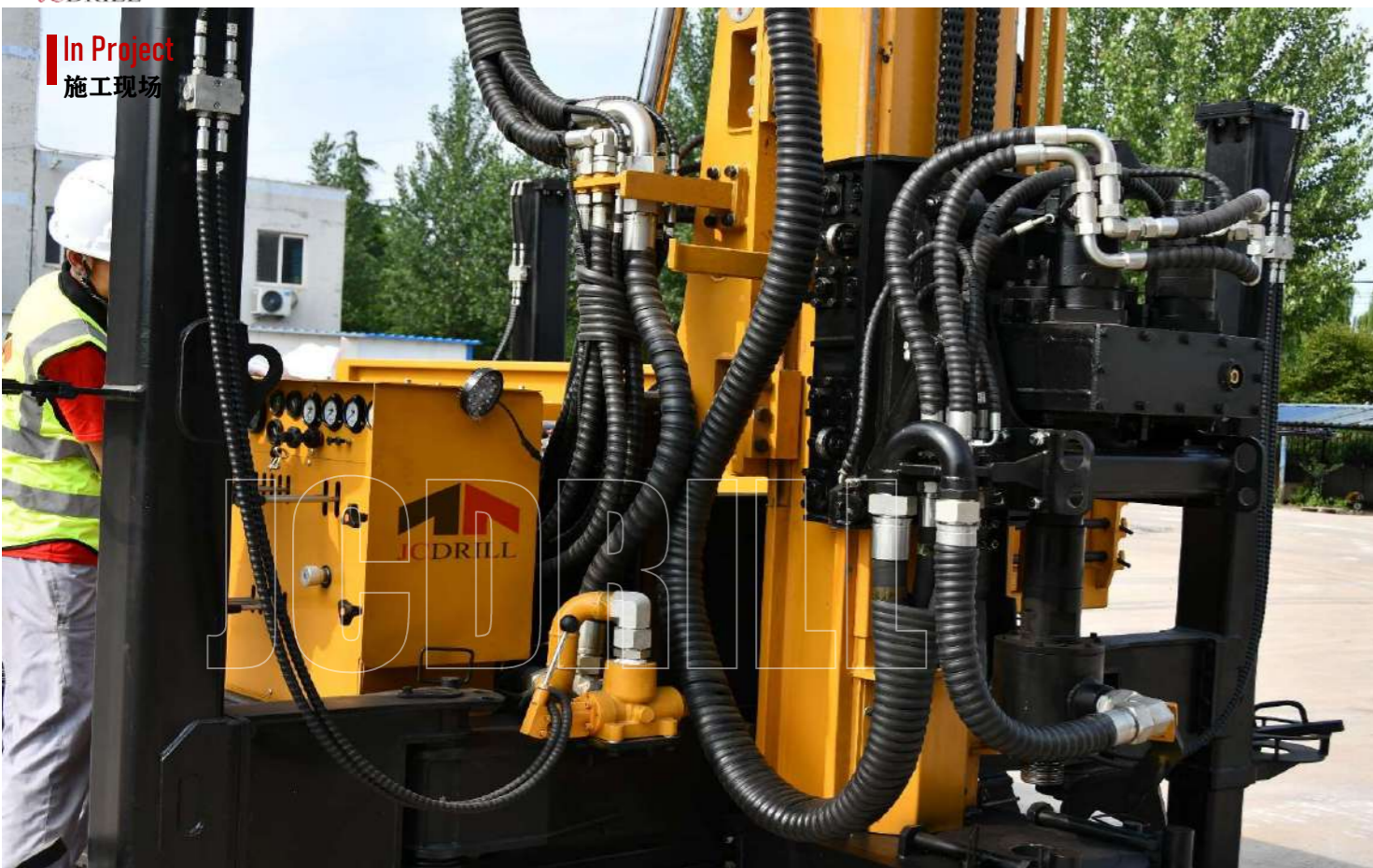

Contact Us  
联系我们

BEIJING JINCHENG MINING TECHNOLOGY CO., LTD

Add: Rm1407, Building A, NO. 13 Beiyuan Road, Chaoyang, Beijing, China

Mob: 0086 13810203890

Tel: 0086 10 84673566

Fax: 0086 10 51617069

Email: sales@jcdrill.com

Web: www.jcdrill.com

WhatsApp/Viber/Wechat: +8613810203890



WECHAT



WHATSAPP



WWW.JCDRILL.COM

RC Drilling Rig  
反循环钻机

