

JRC500T

JRC500T REVERSE CIRCULATION DRILLING

RIG JRC500T系列反循环钻机

RC DRILLING KNOW HOW 什么是反循环

- >> Reverse Circulation is a drilling method widely used around the world.
- >> RC drilling uses dual wall drill rods consisting of an outer drill rod with an inner tube. These hollow inner tubes allow the drill cuttings to return back to the surface in a continuous, steady flow.
- >> The advantage of this drilling technique is that it produces large quantities of high quality, reliable samples free of cross-contamination. The cuttings also allow surveyors to locate mineral deposits more precisely as the samples are identified by the exact depth and location that they were found.
- >> RC drilling produces dry rock chips, large air compressors dry the rock ahead of the advancing drill bit. It is slower, but achieves better penetration than other types of drilling.
- >> Conventional DTH and Top Hammer collar sampling are likely to experience unwanted material collection, as the desired sample is blown to the surface via the hole annulus and contaminated by the prior sample intervals.
- >> As a result, Reverse Circulation drilling results are successfully used in resource calculations worldwide.

JRC500T CHARACTERISTICS 主要特点

- > JRC500T reverse circulation drilling rig is a new multi-purpose, high-efficiency, environmental protection, multi-track-type rig, which uses the latest foreign gas lift reverse circulation drilling technology, rock dust can be effectively collected through a dust collector to avoid environmental pollution. You can also collect slagging cyclone separator can be used in geological prospecting department of sampling analysis. It is a geological exploration drilling, drilling wells, monitoring wells, ground source heat pump air-conditioning and other deep hole of choice for equipment.
- > The drilling rig can be used in a variety of compressed air on the ground hole reverse circulation drilling. The lifting system, guide compensation, drill pipe loading and unloading, rotation and feed, legs, winch, and other system to achieve all of the hydraulic system to significantly reduce the labor intensity and improve the efficiency and quality of construction .



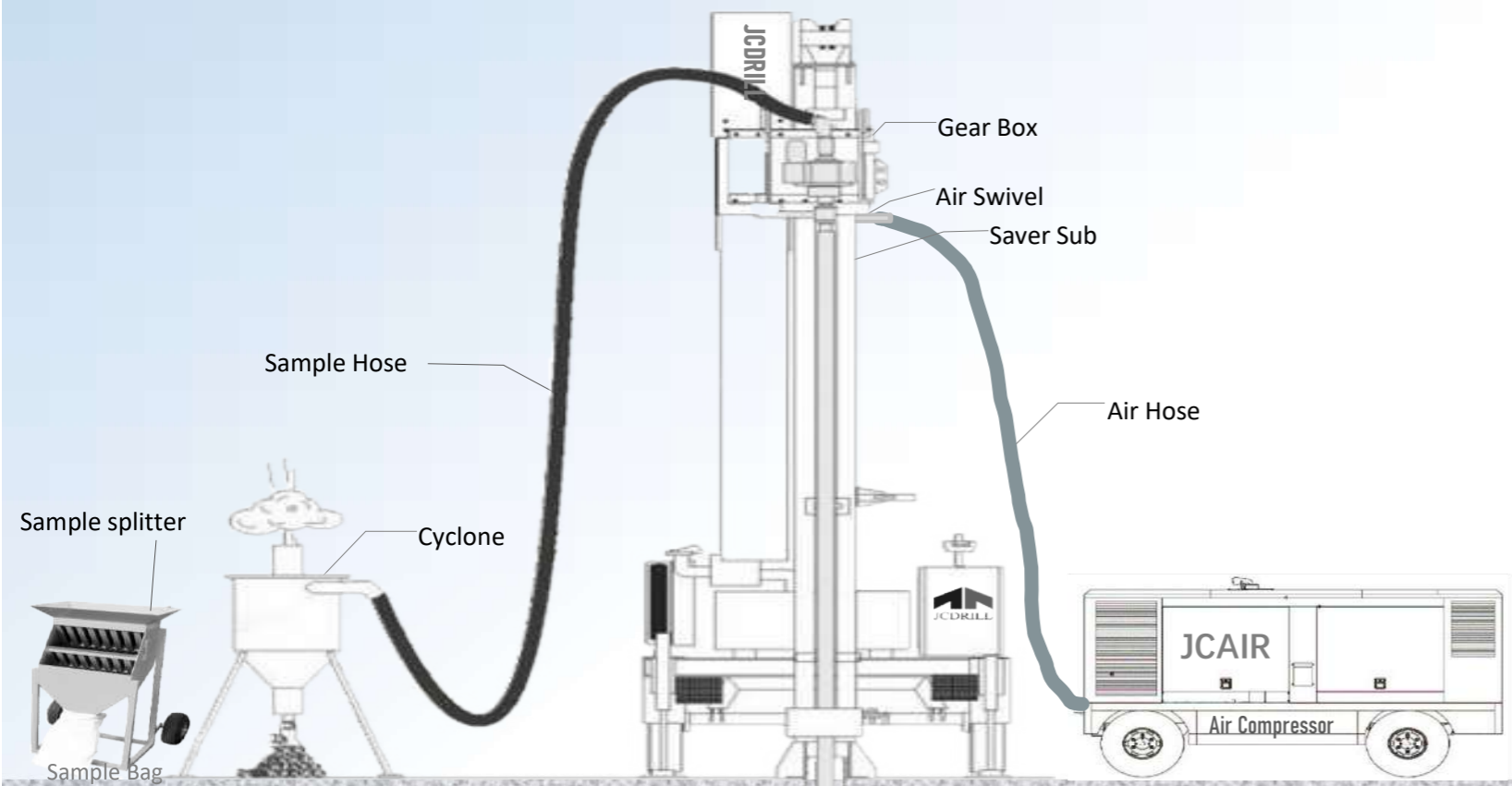

Bottom of Hole

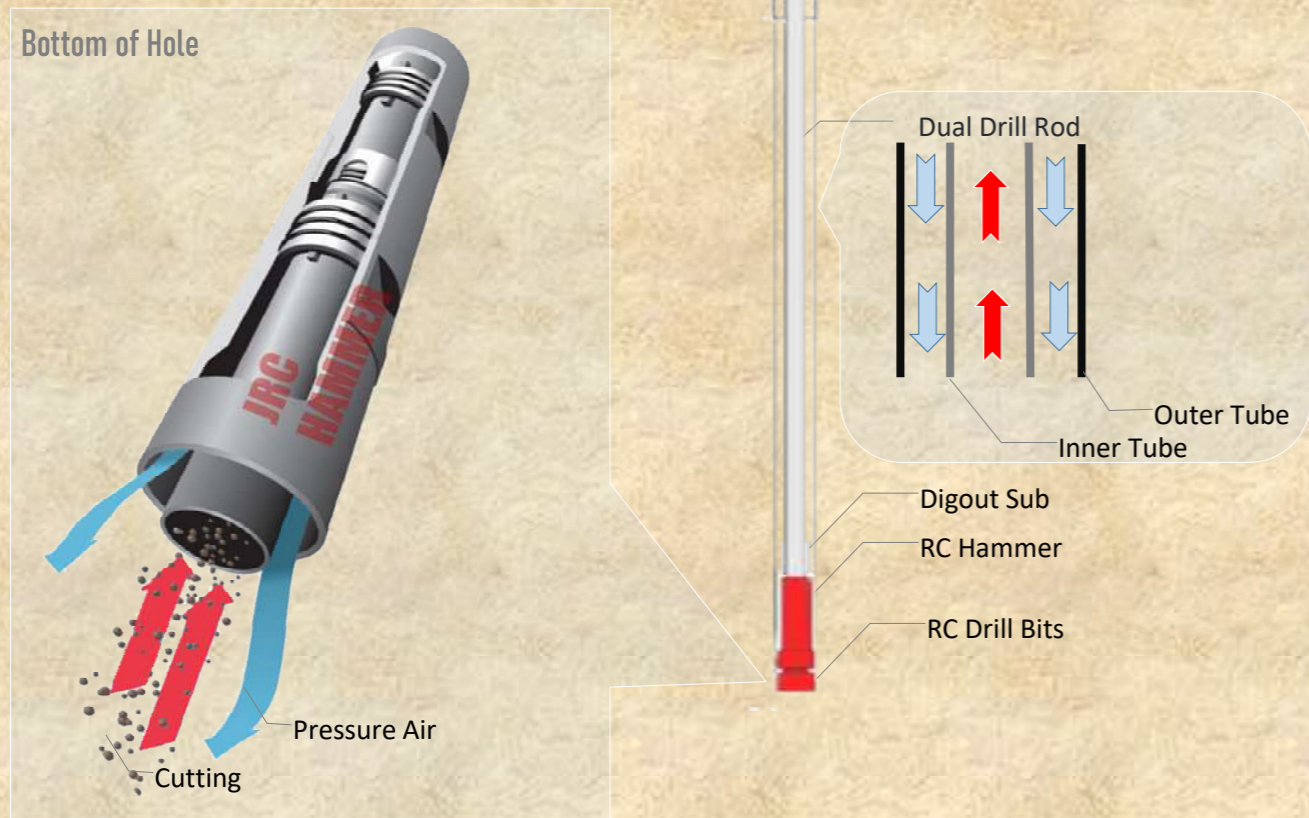

JRC SERIES

REVERSE CIRCULATION DRILLING RIG

反循环钻机



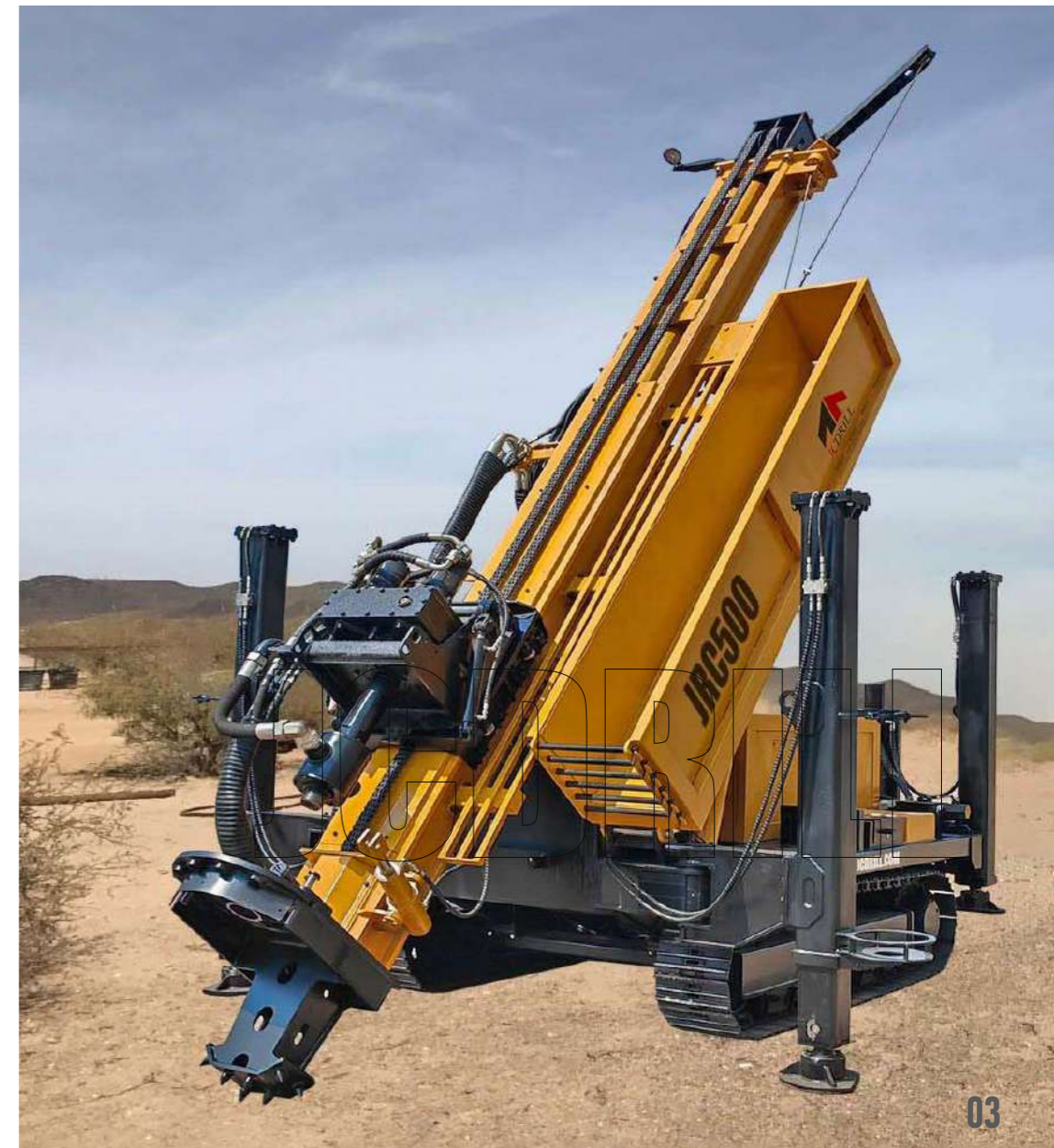

Characteristics 产品特点

- >> Diesel engine mounted hydraulic system, all the system include the walking, rotation, feed, lifting, Leg, lifting, compensation system, rod change is hydraulic.
- >> Reverse circulation system working together with DTH technology, air compressor provide pressed air for impact and dust collect.
- >> During working, use the reverse circulation hammer, double tube, pressed air enter between two tube and dust out from the inner tube.
- >> Also it's available to positive circulation use normal drilling tool.
- >> The working system composed of feed system, guide(mast), rotary head, compensation system, centralizer, rod exchange system, winding and so on.
- >> Axes pressure, feed speed, rotary speed is adjustable.

Specification 技术参数

Spc.	Unit	Data.
Geology drilled		All kinds
Drilling Type		DTH & RC
Drill system and operation		Hydraulic
Max.Hole Diameter	mm	105-450
Max.Hole Depth	m	500
Rotation Torque	N.M	14000
Rotation Speed	rpm	0-40-80
DTH Drill pipe diameter	mm	89/102/114
RC Drill pipe diameter	mm	89/102/114
Drill pipe length	mm	3000
Max. Feed Speed	M/min	5-30
Max. Lifting Speed	M/min	5-18
Feed Stroke	mm	3700
Pull back Capacity	T	34
Lifting force of tool winch	T	1.5
Lifting height of tool winch	m	7.5
Engine		
Diesel Engine type	CUMMINS	
Rated Horse power	Kw	132
Electrical System	Volt	24
Compressor required		
Pressure Required	Mpa	1.05—4.5
Air consumption	m³/min	16—60
Dimension		
Net Weight	T	22.5
Shipping Dimension	mm	11600*2550*3550

Optional Device

Rotary head Swing / Rod Box Swing / Blow Down Valve / Winch Arm Swing / Hydraulic Generator

I Main Component

- > Sinotruk, Foton, Dongfeng, FAW truck 6x4 or 8x4
- > Cummins engine 132KW
- > 3m RC drill pipe length
- > Cyclone & sample splitter on board
- > 35bar air compressor on board
- > Operation panel removable
- > Hydraulic clamp
- > Rotary motor from EATON(USA brand)



JCDRILL

The best RC drilling solution!



PROFESSIONAL TEAM



QUALITY GUARANTEED



24 HOURS ONLINE



24 HOURS SERVICE



JCDRILL

JRC300S IN MIDDLE ASIA



JCDRILL

JRC500A IN MONGOLIA



>> We provide gear box driven by two hydraulic motor, which can use for 150/200/300/400/500m and 115 to 178mm RC hole drilling.

>> The side inlet swivel distributes pressure air in between the outer tube and inner tube.

>> The saver sub protects the threads on the rotation head. The saver sub thread comes into contact with all the other thread in the drill string and should be replaced frequently to reduce the risk of adamaged

>> The dual-wall pipe supplies air to the hammer through the annulus between the inner and outer pipe, and transports cuttings inside the inner tube for sampling.

>> A digout sub is a short crossover sub between the hammer and pipes. With 4 bars, It stabilizes the hammer and prevents damaged to the hammer when digging out

>> High frequency reverse circulation hammer offer worldclass performance and reliability in all rock formation, with 15-20 percent higher penetration than conventional tools.

Reverse Circulation

We offer a complete RC drilling string.

Scan here to find us



WECHAT



WHATSAPP

JCDRILL

RC hammer & Bits 4-7"

RC Drilling Rigs
反循环钻机



JRC200



JRC300



JRC400



JRC500



JRC150

RC Drilling Products
反循环相关产品



Air Compressor

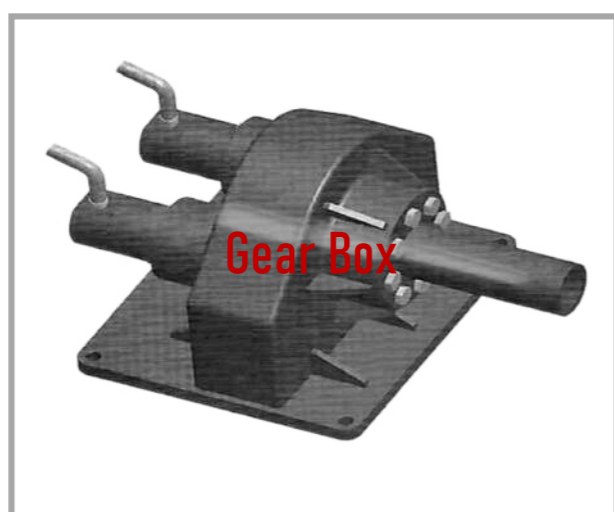

Gear Box



Hammer & RC Bits



Digout Sub & Safty sub



Air Swivel



RC Chip Trays



Air hose & Discharge Tube



Drill rod



Sample Splitter



Cyclone



Shipping 运输



WWW.JCDRILL.COM

RC Drilling Rig
反循环钻机

JCDRILL



Contact Us 联系我们

BEIJING JINCHENG MINING TECHNOLOGY CO., LTD

Add: Rm1407, Building A, NO. 13 Beiyuan Road, Chaoyang, Beijing, China

Mob: 0086 13810203890

Tel: 0086 10 84673566

Fax: 0086 10 51617069

Email: sales@jcdrill.com

Web: www.jcdrill.com

WhatsApp/Viber/Wechat: +8613810203890



WECHAT



WHATSAPP

